

4 3 2 1

D  
C  
B  
A

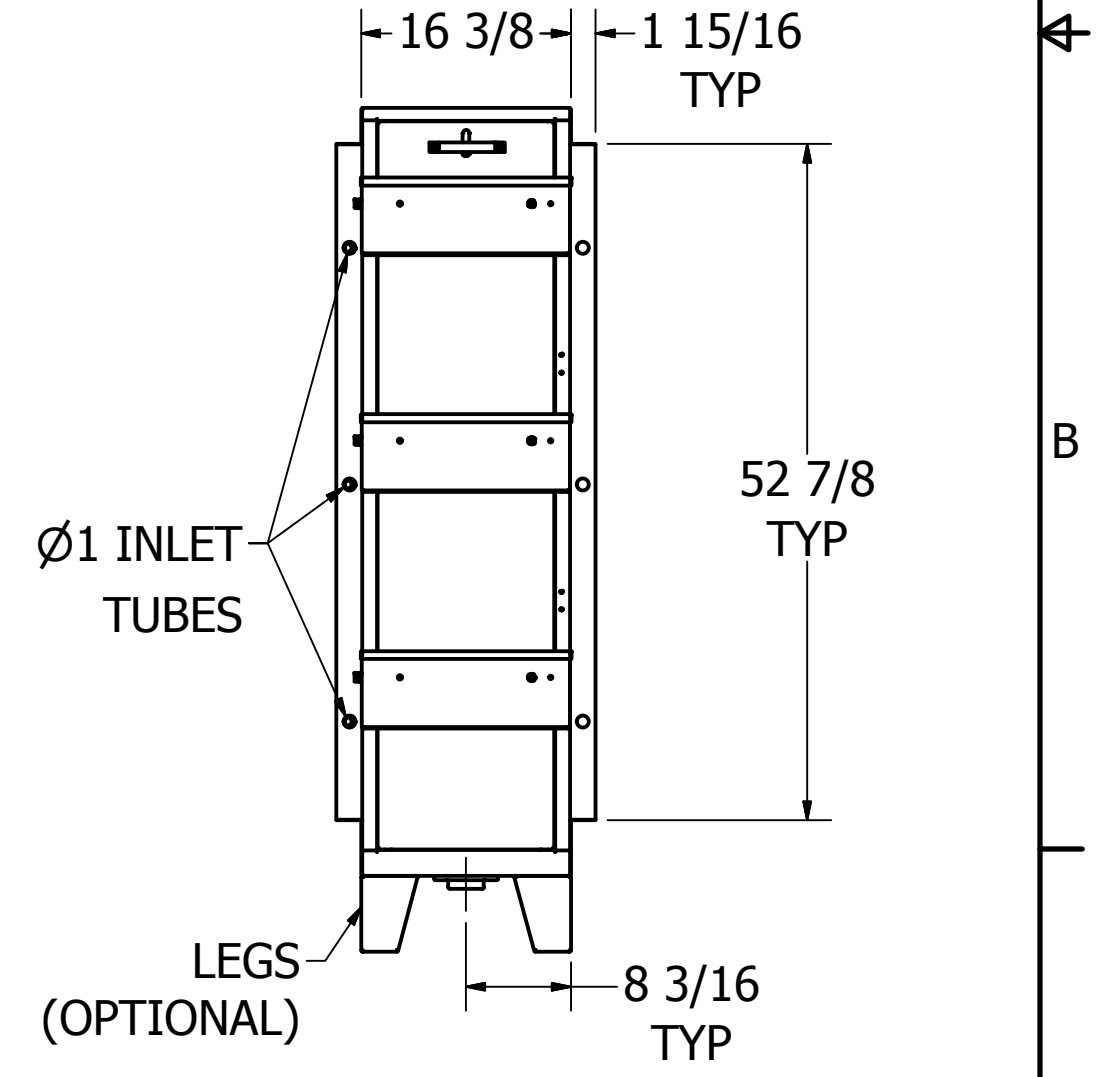
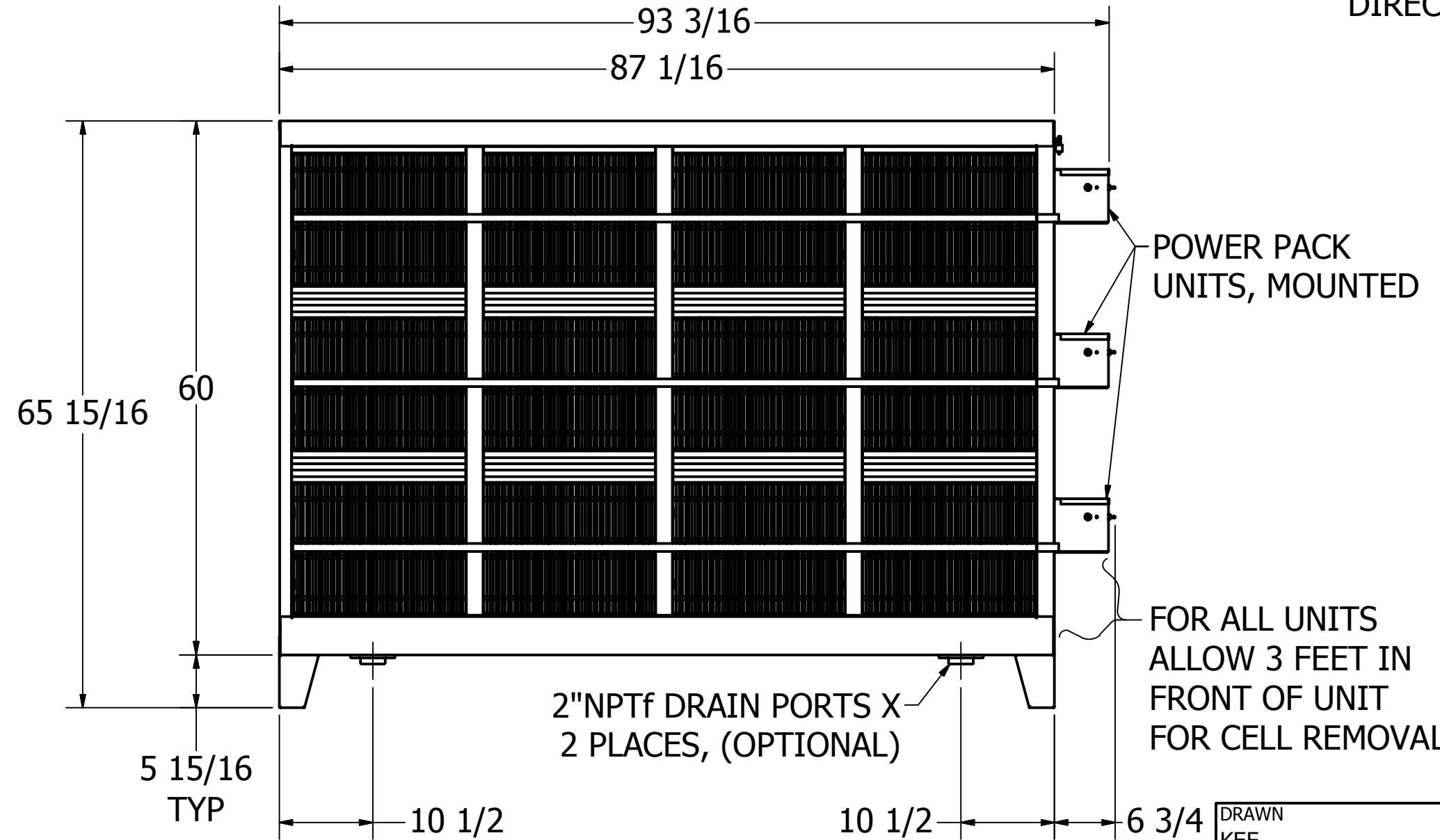
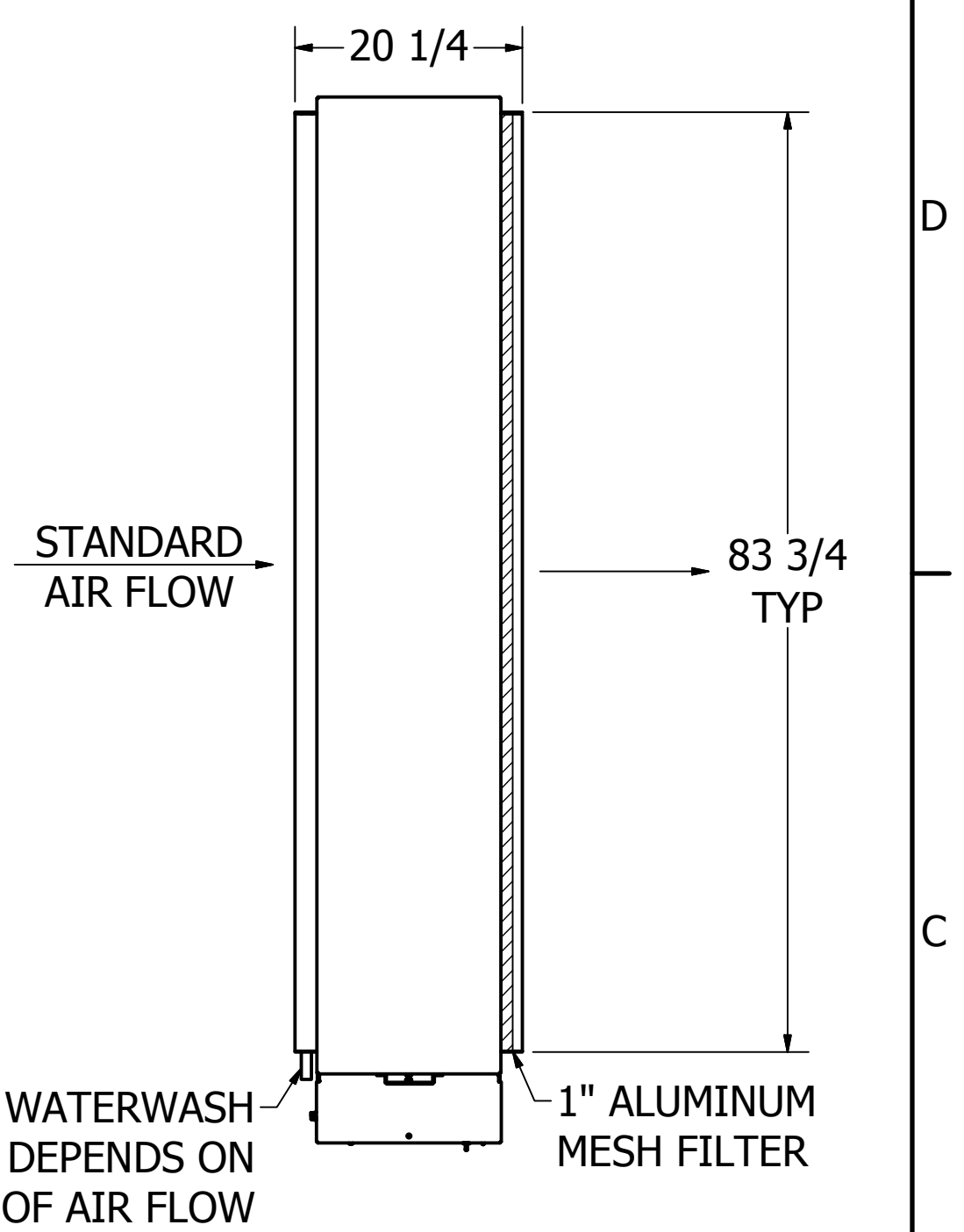
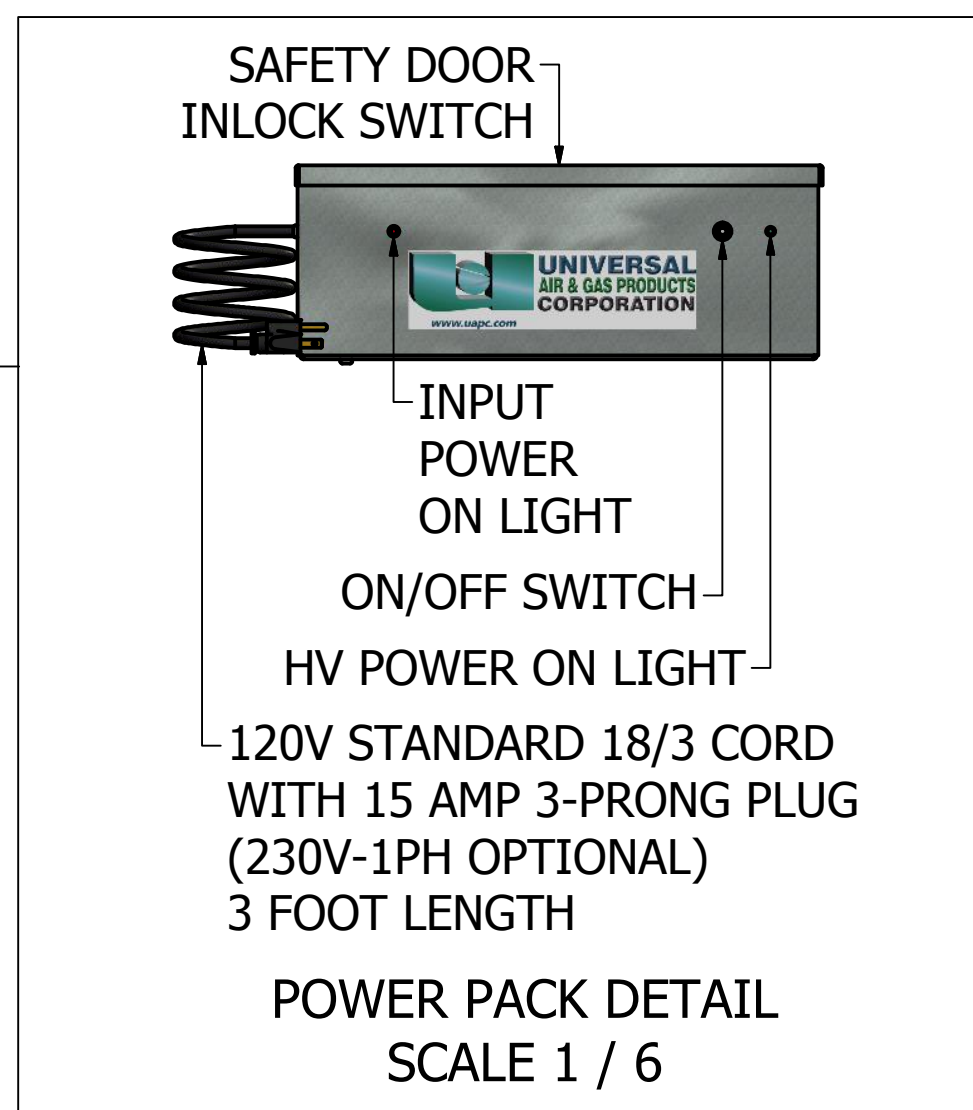
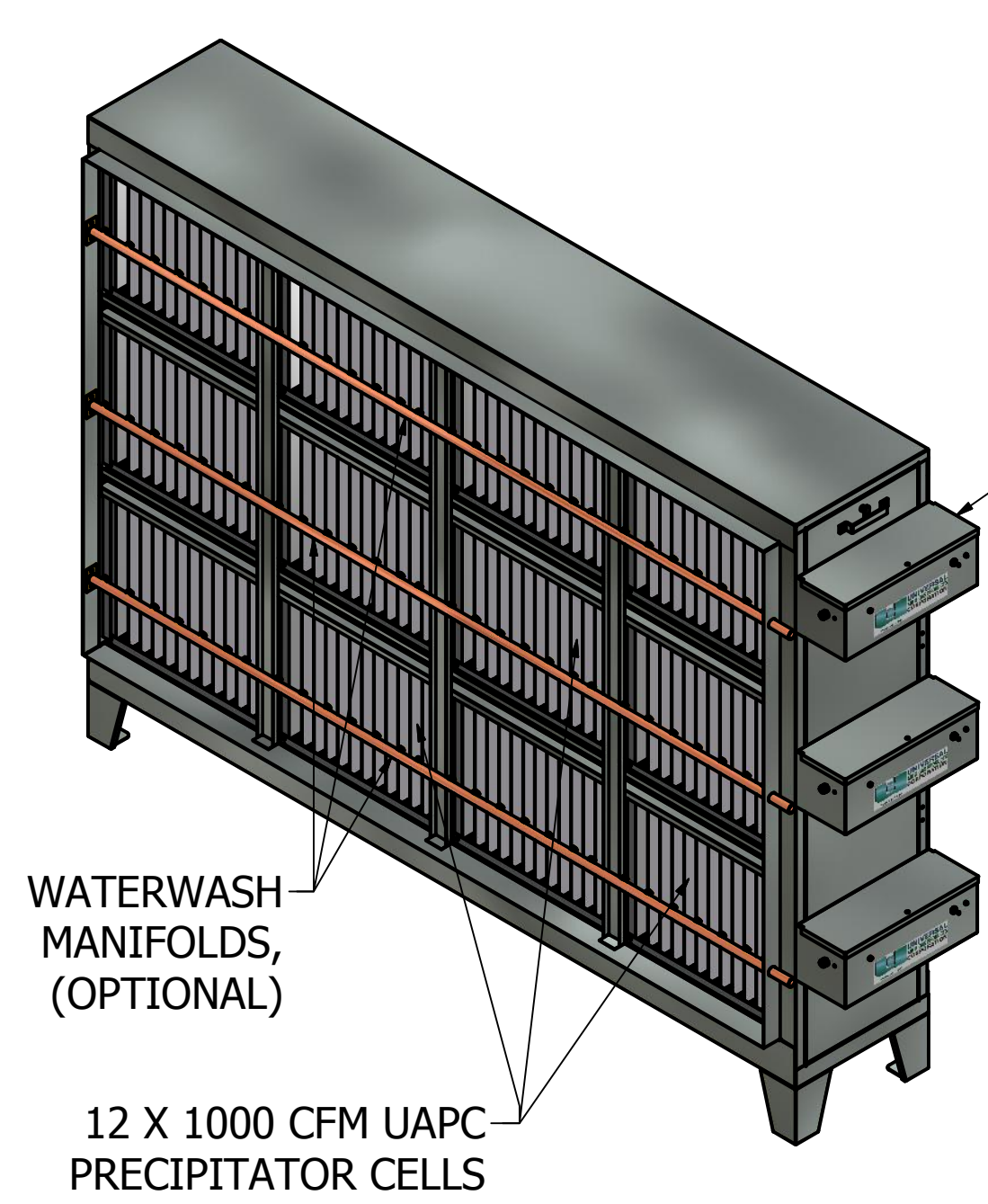

NOTE: REMOTE POWER PACK PROVISIONS AVAILABLE AS AN OPTION.

**COMPANY CONFIDENTIAL**

This drawing and all information herein is the property of Universal Air Products Corp. It is confidential and must not be made public or copied. It is loaned, subject to return upon demand. It is not to be used directly or indirectly in any way detrimental to the interests of UNIVERSAL AIR PRODUCTS.

DRAWN KEF	6/30/2014	UNIVERSAL AIR & GAS PRODUCTS CORP. 1140 KINGWOOD AVE NORFOLK, VA 23502	
CHECKED		TITLE	
QA		C3-120H3: 12000 CFM COMMERCIAL 3 HIGH i3-120H3: 12000 CFM INDUSTRIAL 3 HIGH	
MFG		SIZE C	REV B
APPROVED		DWG NO 3-120H3	
SCALE 1/15		SHEET 1 OF 1	

4 3 2 1