

4

3

2

1

D

D

C

C

B

B

A

A

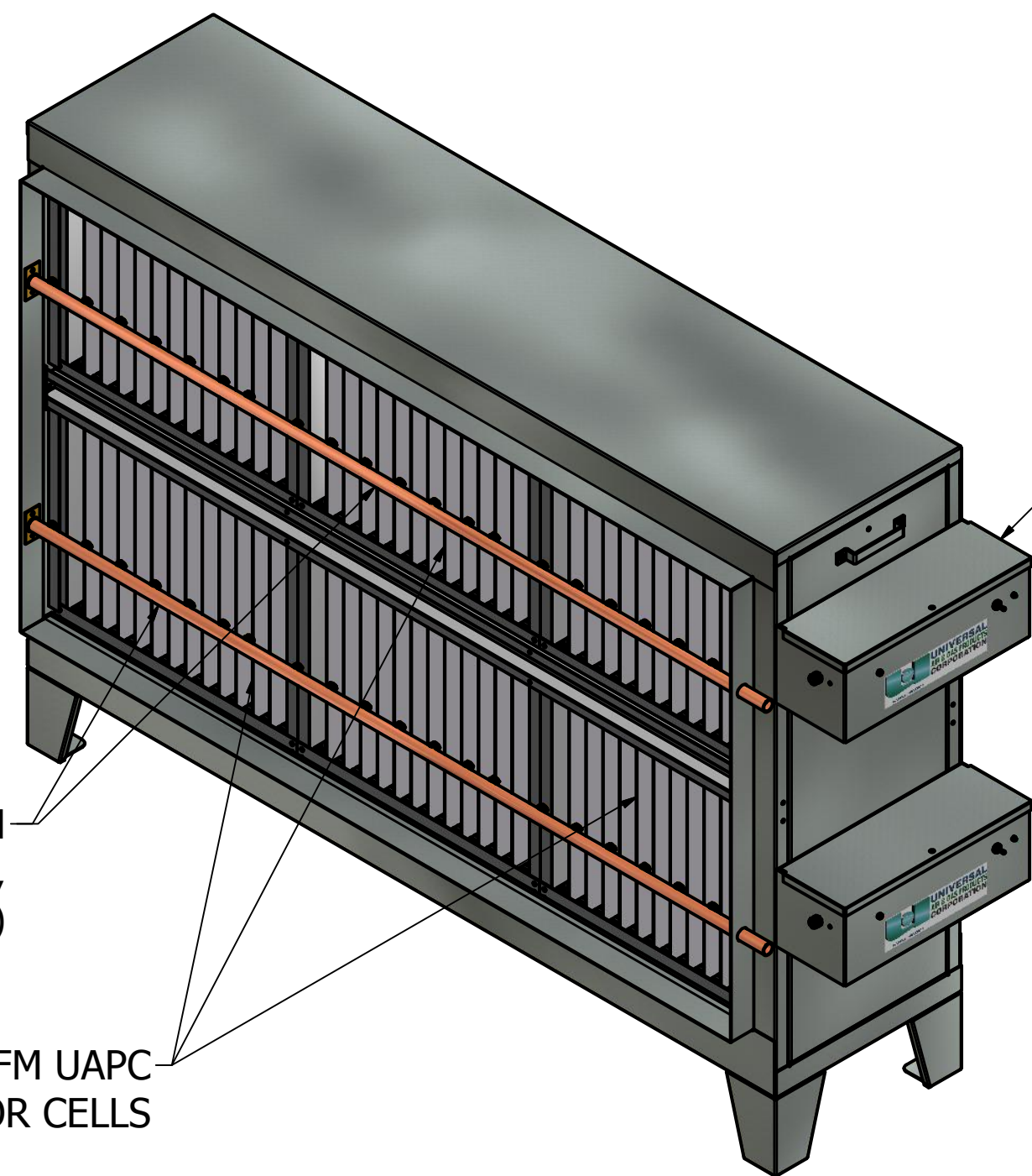

WATERWASH  
MANIFOLDS,  
(OPTIONAL)

6 X 1000 CFM UAPC  
PRECIPITATOR CELLS

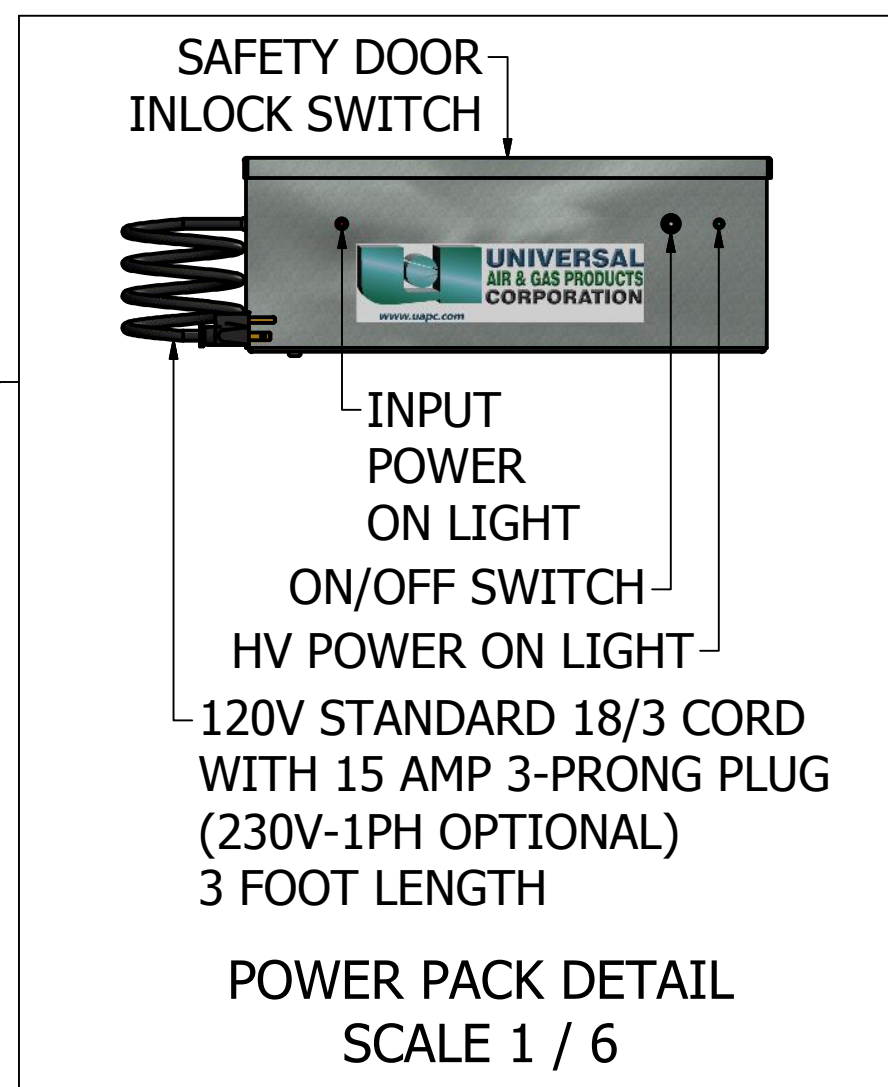

STANDARD  
AIR FLOW

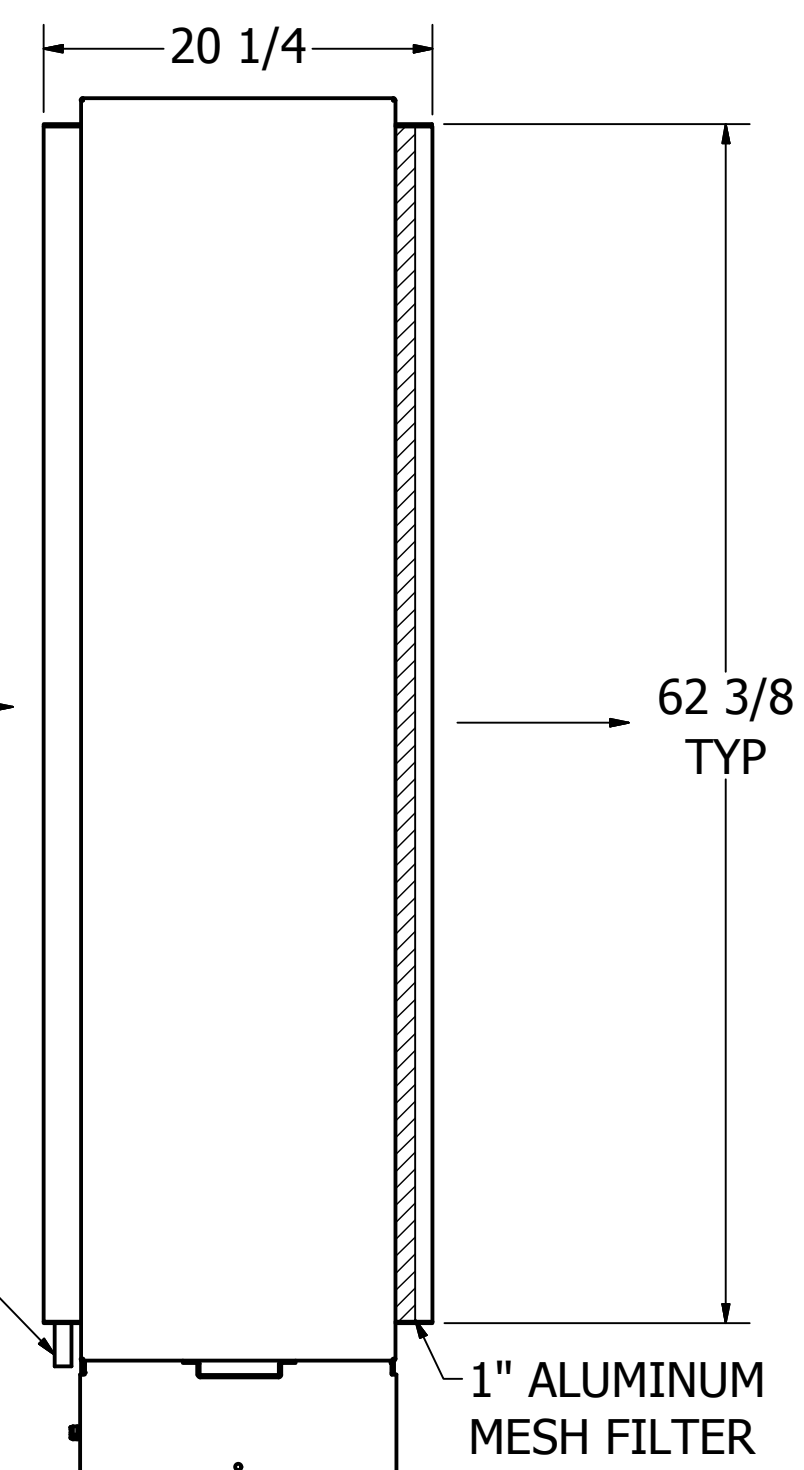

LOCATION OF WATERWASH  
MANIFOLDS DEPENDS ON  
DIRECTION OF AIR FLOW

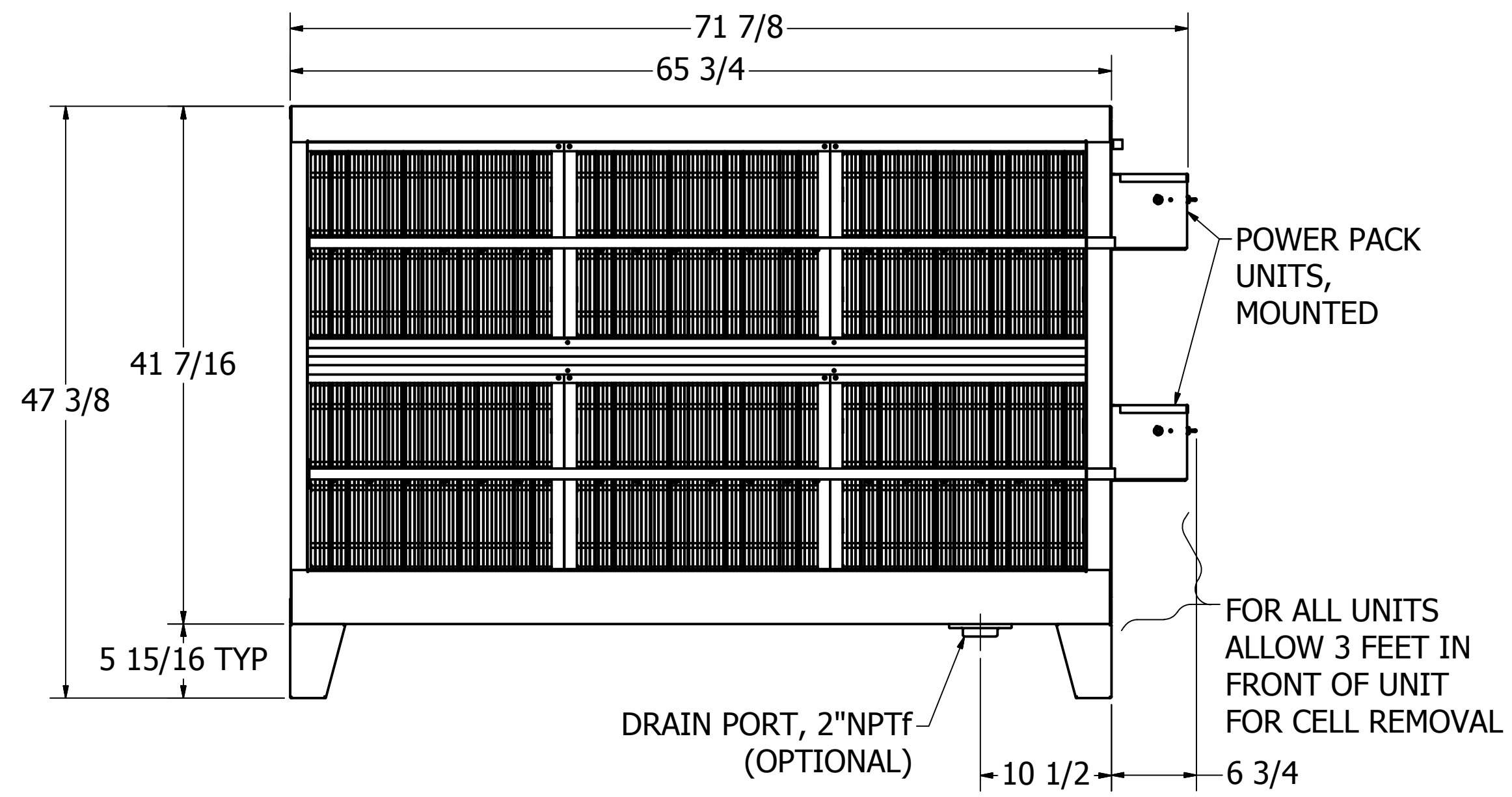
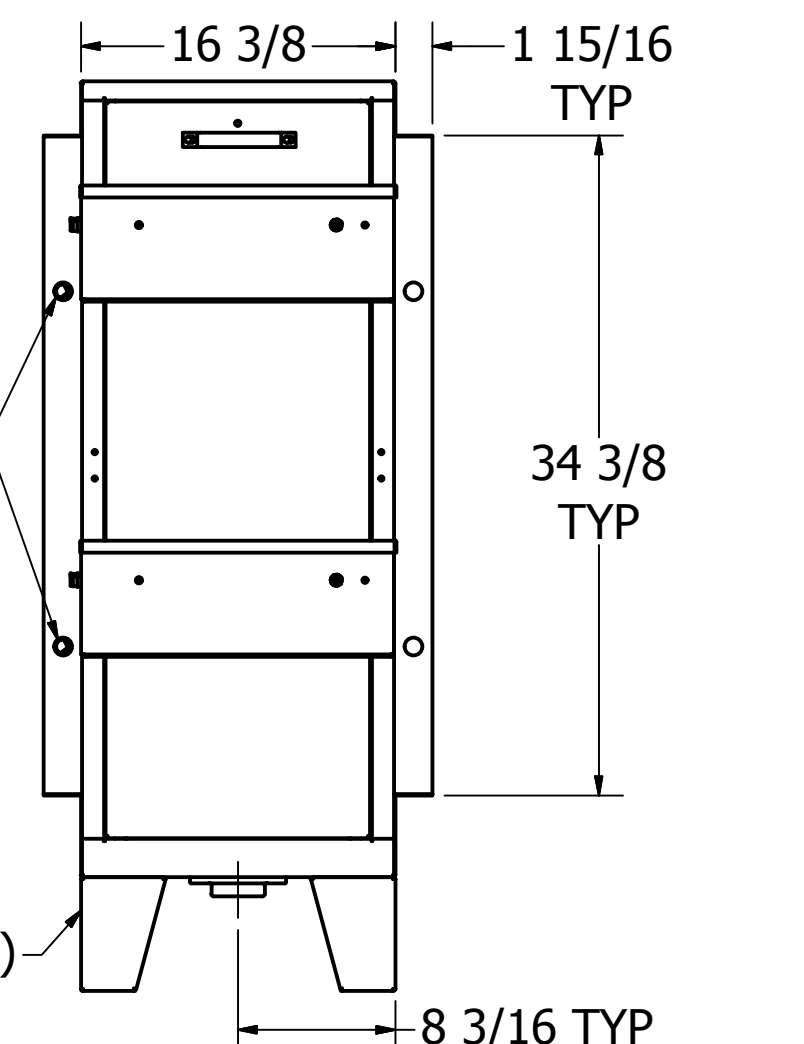

Ø3/4 INLET TUBES

LEGS (OPTIONAL)

NOTE: REMOTE POWER PACK PROVISIONS  
AVAILABLE AS AN OPTION.

**COMPANY  
CONFIDENTIAL**  
This drawing and all information herein is the  
property of Universal Air Products Corp. It is  
confidential and must not be made public or  
copied. It is loaned, subject to return upon  
demand. It is not to be used directly or  
indirectly in any way detrimental to the interests  
of UNIVERSAL AIR PRODUCTS.

DRAWN KEF	6/20/2014	UNIVERSAL AIR & GAS PRODUCTS CORP. 1140 KINGWOOD AVE NORFOLK, VA 23502	
CHECKED		TITLE	
QA		C3-60H2: 6000 CFM COMMERCIAL 2 HIGH i3-60H2: 6000 CFM INDUSTRIAL 2 HIGH	
MFG		SIZE C	REV B
APPROVED		DWG NO 3-60H2	
SCALE 1/10		SHEET 1 OF 1	